



FKS™ Series: F600@40 - F1000@36 125" Wheelbase

LP-, gasoline-, diesel-powered liftruck®
Capacities: 60,000 lbs. - 100,000 lbs.

FKS™ Series liftrucks®

The FKS™ Series liftruck® is the essential tool for maximum productivity. Combined with a wide range of available capacities, masterfully engineered ergonomics strengthen the already superior performance of FKS™ Series trucks.

Operator environment

HOIST® engineered the FKS™ for maximum productivity, with a cab environment configured around the fatigue-reducing needs of human operators.

- Rubber-mounted cab, isolated from frame to reduce noise and vibration: noise levels as low as 77 decibels
- Low profile for unmatched 360° visibility
- Adjustable semi-suspension seat equipped with hip restraints, retractable seat belts
- Optional "Air-Ride" seat
- Center- or left-side-mounted cab
- 18 In. step for easy access from both sides
- Several riser options available for maximum visibility
- Easy entry/exit design, non-skid steps
- Padded floor cover
- Tilt-steering column
- Illuminated digital instrument display
- "Soft-touch" hydraulic levers
- Column-mounted directional shifter
- Horn button and steering knob mounted on steering wheel

Engines

- Standard GM 7.4L V8
 - Horsepower: max. 190 @ 2500 rpm
 - Torque: max. 380 lbf-ft @ 1800 rpm
- LP gas standard (tanks not included)
 - Low-mount, swing-out LP tank brackets
- Gasoline or dual fuel options available
- Optional diesel: Cummins 5.9L I-6
 - Horsepower: max. 152 @ 2500 rpm
 - Torque: max. 414 lbf-ft @ 1600 rpm

Transmission and drive axle

- HOIST® 3-speed Powershift (Autoshift) designed for heavy-duty operation
- Electronically-controlled 12-plate modulation

for closer gear ratios and smooth shifting

- Powershift (Autoshift) frees operator from gear-shifting to concentrate on work tasks
- Inching controls provide smooth operation in or out of loads
- Externally mounted pump and integral filter allow easy maintenance
- Traction load axle: heavy-duty, planetary drive axle designed for high load capacities, extended service life and reduced maintenance
 - All gears heat-treated, precision-ground

Hydraulic system

Soft-touch control levers allow smooth, comfortable, controlled operation.

- Load-sensing, on-demand system provides smooth and reliable control while limiting demand on the powerplant
- Piston pump provides superior control and quiet operation
- Fuse in lift cylinder protects against sudden loss of pressure. If lift hose breaks, lift cylinder locks safely in position
- Optional tilt cab for complete access to powertrain and hydraulic system

Steering system

Heavy-duty steer axle features heavy alloy steel plate sections around single, double-acting cylinder.

- Full turn of wheels provides maneuverability in tight areas while maintaining directional tracking of tire, with no skidding or premature tire wear

Brakes

Large drum-type braking surfaces provide ample capacity, reliability and ease of use.

- No overheating or "glazing"
- Hand-actuated disc-type parking brake with instrument panel warning light warns operator when brake is engaged

Mast design

Heavy-duty mast rails provide superior visibility and full capacity at maximum lift heights.

- Mast options available for widely varying

needs: consult factory for more information

Carriages

High-visibility carriage allows maximum productivity.

- Integral side-thrust rollers provide uncompromised strength and visibility

Forks

Pallet forks standard (must specify). Optional pin-mount, machine-contoured forks provide maximum strength and visibility without damaging loads.

Options

- Tilting cab conveniently reveals instant access to powertrain and hydraulic system
- Hydraulic floating cab for operator comfort eliminates vibration, ideal for operation in rough terrain/on uneven flooring surfaces
- Cab heater, windshield wiper and defroster for cold weather applications
- Air conditioning
- Fire-safe fluids
- Special attachments and tools
- See your HOIST® dealer for more information!

Serviceability

The HOIST® FKS™ Series truck is engineered with your mechanic in mind: all components are well-placed for convenient access and ease of maintenance:

- Hinged side doors (with gas cylinder supports) provide easy access to engine compartment
- Hydraulic pump, hoses and tubes and wiring harnesses are accessible and easy to inspect

Safety

The FKS™ Series chassis and rims are painted high-visibility "HOIST® yellow". The mast and overhead guard are painted anti-glare black. The truck complies with all currently valid ANSI, OSHA, CE, and EU directives for industrial trucks, and arrives standard with the following:

- Audible backup alarm
- Two adjustable headlights, two tail/stop/turn indicators
- Amber strobe warning light



Liftruck specifications: FKS™ Series, 125" Wheelbase

			HOIST®	HOIST®	HOIST®		HOIST®	HOIST®	HOIST®	HOIST®		
General	1	Manufacturer	HOIST®	HOIST®	HOIST®		HOIST®	HOIST®	HOIST®	HOIST®		
	2	Model	F600@40	F650@36	F700@36		F750@36	F800@36	F800@40	F900@36		
	3	Capacity, rated	lb. (kg)	60,000 (27240)	65,000 (29510)	70,000 (31780)		75,000 (34050)	80,000 (36320)	80,000 (36320)	90,000 (40860)	
	4	Load center	lb. (kg)	40 (1016)	36 (914)	36 (914)		36 (914)	36 (914)	40 (1016)	36 (914)	
	5	Power type		gas/LP/diesel	gas/LP/diesel	gas/LP/diesel		gas/LP/diesel	gas/LP/diesel	gas/LP/diesel	gas/LP/diesel	
	6	Operator type		sitdown	sitdown	sitdown		sitdown	sitdown	sitdown	sitdown	
	7	Tire type, front/rear		solid/solid	solid/solid	solid/solid		solid/solid	solid/solid	solid/solid	solid/solid	
	8	Wheels, front/rear	x=driven	2/2	2/2	2/2		2/2	2/2	2/2	2/2	
Dimensions	10	Limited free-lift monomast (LFL), (TOF)	in. (mm)	48 (1219)	48 (1219)	48 (1219)		70.5 (1791)	70.5 (1791)	70.5 (1791)	70.5 (1791)	
	11	Limited free-lift (TOF)	in. (mm)	48 (1219)	48 (1219)	48 (1219)		70.5 (1791)	70.5 (1791)	70.5 (1791)	70.5 (1791)	
	12	Optional 3-stage full free-lift (FFL), (TOF) with / w/o LBR	in. (mm)	N/A	N/A	N/A		N/A	N/A	N/A	N/A	
	13	Forks, width/thickness	in. (mm)	4.5 x 10 (114 x 254)	4.5 x 10 (114 x 254)	5 x 10 (127 x 254)		5 x 10 (127 x 254)	5 x 10 (127 x 254)	5 x 11 (127 x 279)	5.25 x 11 (133 x 279)	
	14	Tilt angle, forward/backward	degree	9°/9°	9°/9°	9°/9°		9°/9°	9°/9°	9°/9°	9°/9°	
	15	Length to face of forks	in. (mm)	185.5 (4712)	190 (4826)	190 (4826)		190 (4826)	190 (4826)	190 (4826)	197 (5004)	
	16	Overall width, standard tires	in. (mm)	82 (2083)	97 (2464)	97 (2464)		97 (2464)	97 (2464)	97 (2464)	105 (2667)	
	17	Height, standard monomast lowered	in. (mm)	126 (3200)	126 (3200)	156 (3962)		156 (3962)	156 (3962)	156 (3962)	176 (4470)	
	18	Height, standard mast ext. - w/o LBO	in. (mm)	126 (3200)	126 (3200)	156 (3962)		156 (3962)	156 (3962)	156 (3962)	156 (3962)	
	19	Turning radius, minimum outside	in. (mm)	182.5 (4636)	187 (4750)	187 (4750)		187 (4750)	187 (4750)	187 (4750)	191.5 (4864)	
	20	Center of drive wheel to face of forks	in. (mm)	29 (737)	29 (737)	29 (737)		29 (737)	29 (737)	29 (737)	37 (4470)	
	22	Aisle width	in. (mm)	166.5 (4229)	171 (4343)	171 (4343)		171 (4343)	171 (4343)	171 (4343)	181 (4597)	
	23	Stability (comply with ANSI, CE)*		Yes	Yes	Yes		Yes	Yes	Yes	Yes	
	Performance	24	Travel speed, powershift	empty/loaded mph (km/hr)	8.5 (13.6)	8.5 (13.6)	8.5 (13.6)		8.5 (13.6)	8.5 (13.6)	8.5 (13.6)	8.5 (13.6)
		25	Lift speed, standard mast empty/loaded	ft./min (m/s)	13 seconds	13 seconds	13 seconds		15 seconds	15 seconds	15 seconds	15 seconds
		Opt. 3-stage full free-lift (FFL)	empty/loaded ft./min (m/s)	total travel	total travel	total travel		total travel	total travel	total travel	total travel	
26		Lowering, std. mast, NL/RL	ft./min (m/s)	adjustable	adjustable	adjustable		adjustable	adjustable	adjustable	adjustable	
		Opt. 3-stage full free-lift (FFL)	empty/loaded ft./min (m/s)	adjustable	adjustable	adjustable		adjustable	adjustable	adjustable	adjustable	
27		Drawbar pull, powershift, max. 1 mph	lb. (kN)	36,781 (164)	36,781 (164)	36,781 (164)		36,781 (164)	36,781 (164)	36,781 (164)	36,781 (164)	
28	Gradeability @ .9 coef.	empty/loaded	38/45	38/45	32/43		25/30	24/29	23/27.5	22/25.5		
Weight	30	Total approximate weight, standard truck	lb. (kg)	72,100 (32733)	80,800 (36727)	84,600 (38455)		85,500 (38817)	86,200 (39135)	87,530 (39786)	89,750 (40795)	
	31	Axle loading, static, front	empty/loaded lb. (kg)	30,010 (13641)/123,040 (55968)	31,600 (14364)/138,200 (62818)	31,600 (14364)/146,400 (66545)		31,600 (14364)/145,000 (65909)	33,000 (15000)/153,960 (69982)	34,440 (15655)/157,960 (71800)	35,350 (16068)/171,042 (77747)	
		Axle loading, static, rear	empty/loaded lb. (kg)	42,090 (19132)/8,970 (4077)	49,200 (22364)/7,600 (3455)	56,800 (25787)/8,200 (3727)		57,700 (26196)/7,000 (3182)	58,400 (26514)/7,540 (3420)	58,400 (26514)/9,570 (4350)	54,400 (24727)/8,708 (3958)	
Chassis	32	Number tires, front/rear		4/2	4/2	4/2		4/2	4/2	6/2		
	33	Size tires, front		36x12x30	36x16x30	36x16x30		36x16x30	36x16x30	36x12x30	36x12x30	
	34	Size tires, rear		28x14x22	28x14x22	28x14x22		28x14x22	28x14x22	28x14x22	28x14x22	
	35	Wheelbase	in. (mm)	125 (3175)	125 (3175)	125 (3175)		125 (2667)	125 (3175)	125 (3175)	130 (3302)	
	36	Tread width, center of steer tires, single	in. (mm)	60 (1524)	60 (1524)	60 (1524)		60 (1524)	60 (1524)	60 (1524)	60 (1524)	
		Tread width, center of drive tires, single	in. (mm)	57.5 (1460)	65 (1651)	65 (1651)		65 (1651)	65 (1651)	65 (1651)	69 (1753)	
	37	Ground clearance, no load, lowest point	in. (mm)	3.8 (96)	3.8 (96)	3.8 (96)		3.8 (96)	3.8 (96)	3.8 (36)	3.8 (96)	
	38	Ground clearance, no load, center whlbs.	in. (mm)	9.7 (246)	9.7 (246)	9.7 (246)		9.7 (246)	9.7 (246)	9.7 (246)	9.7 (246)	
Drivetrain	39	Brakes, method of control, service/parking		hydraulic/mechanical	hydraulic/mechanical	hydraulic/mechanical		hydraulic/mechanical	hydraulic/mechanical	hydraulic/mechanical	hydraulic/mechanical	
	40	Brakes, method of operation, service/parking		foot/hand	foot/hand	foot/hand		foot/hand	foot/hand	foot/hand	foot/hand	
	42	Battery, volts/cold-cranking amps		12/1150	12/1150	12/1150		12/1150	12/1150	12/1150	12/1150	
	46	Engine, make and model		GM7.4L/Cummins 6BT5.9	GM 7.4L/Cummins 6BT5.9	GM 7.4L/Cummins 6BT5.9		GM 7.4L/Cummins 6BT5.9	GM 7.4L/Cummins 6BT5.9	GM 7.4L/Cummins 6BT5.9	GM 7.4L/Cummins 6BT5.9	
	47	Output per SAE standards, gas/LP/diesel	hp (kW)	LP190 (141)/Diesel 152 (113)	LP190 (141)/Diesel 152 (113)	LP190 (141)/Diesel 152 (113)		LP190 (141)/Diesel 200 (149)	LP190 (141)/Diesel 200 (149)	LP190 (141)/Diesel 200 (149)	LP190 (141)/Diesel 200 (149)	
	48	Governed speed, NL	RPM	2500	2500	2500		2500	2500	2500	2500	
	49	Number of cylinders/displacement		8/7.4L	8/7.4L	8/7.4L		8/7.4L	8/7.4L	8/7.4L	8/7.4L	
	51	Clutch type, powershift		torque converter	torque converter	torque converter		torque converter	torque converter	torque converter	torque converter	
	52	Gear-change type, powershift		hand	hand	hand		hand	hand	hand	hand	
	53	Number of speeds, forward/reverse		3/3	3/3	3/3		3/3	3/3	3/3	3/3	
54	Transmission		Powershift (Autoshift)	Powershift (Autoshift)	Powershift (Autoshift)		Powershift (Autoshift)	Powershift (Autoshift)	Powershift (Autoshift)	Powershift (Autoshift)		
55	Maximum hydraulic pressure	psi (kPa)	2500 (17240)	2500 (17240)	2500 (17240)		2500 (17240)	2500 (17240)	2500 (17240)	2500 (17240)		
58	Sound level avg. at operator's ear per ANSI B56.11.5	dBA	77	77	77		77	77	77	77		

Note: Specifications in this document apply to standard equipment. Actual specifications and performance may vary depending on a truck's spec, its actual condition, and operating environment. Specific applications should be reviewed with a HOIST® dealer.

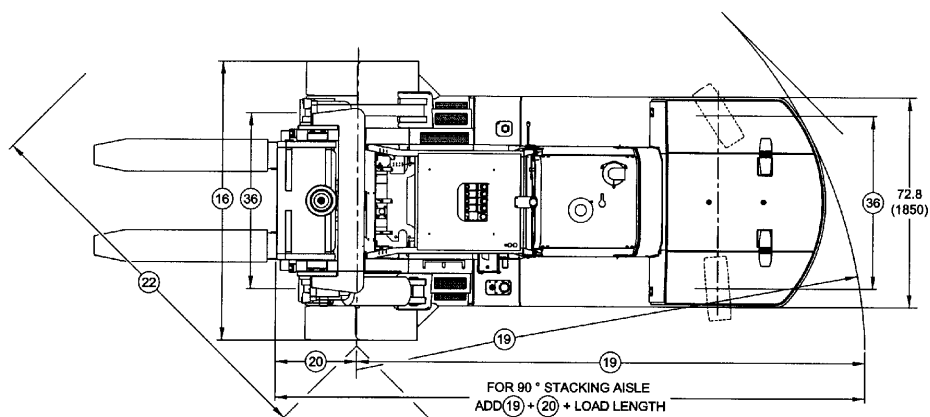

FKS™ Series, 125" wheelbase

Model	Capacity	Load center
F600	60,000 lbs.	40"
F650	65,000 lbs.	36"
F700	70,000 lbs.	36"
F750	75,000 lbs.	36"
F800	80,000 lbs.	36"
F800	80,000 lbs.	40"
F900	90,000 lbs.	36"
F1000	100,000 lbs.	36"

Note: All metric dimensions are not direct equivalents due to rounding data. Specifications subject to change without notice.

Hoist Liftruck Manufacturing, Inc.

6499 W. 65th Street
 Bedford Park, IL 60638
 USA: 800.367.5600
 International: 708.458.2200
 Fax: 708.458.1176
www.hoistlift.com

The HOIST® product line is full of rugged and efficient materials-handling solutions for every aisle, dock and corner of your facility. To learn more about HOIST® products, log on to the Web at www.hoistlift.com. And if you don't see what you need there, talk to us in person at 800.367.5600. We'll work with you.

Legendary reliability:

Built for robustness and designed to last, a HOIST® liftruck® will provide reliable service in the most heavy-duty applications, day after day, year after year.

Ergonomic consideration:

HOIST® engineers design each operator environment for ease of use, superior visibility and comfort.

100% Replacement parts:

In-stock, same-day shipping!

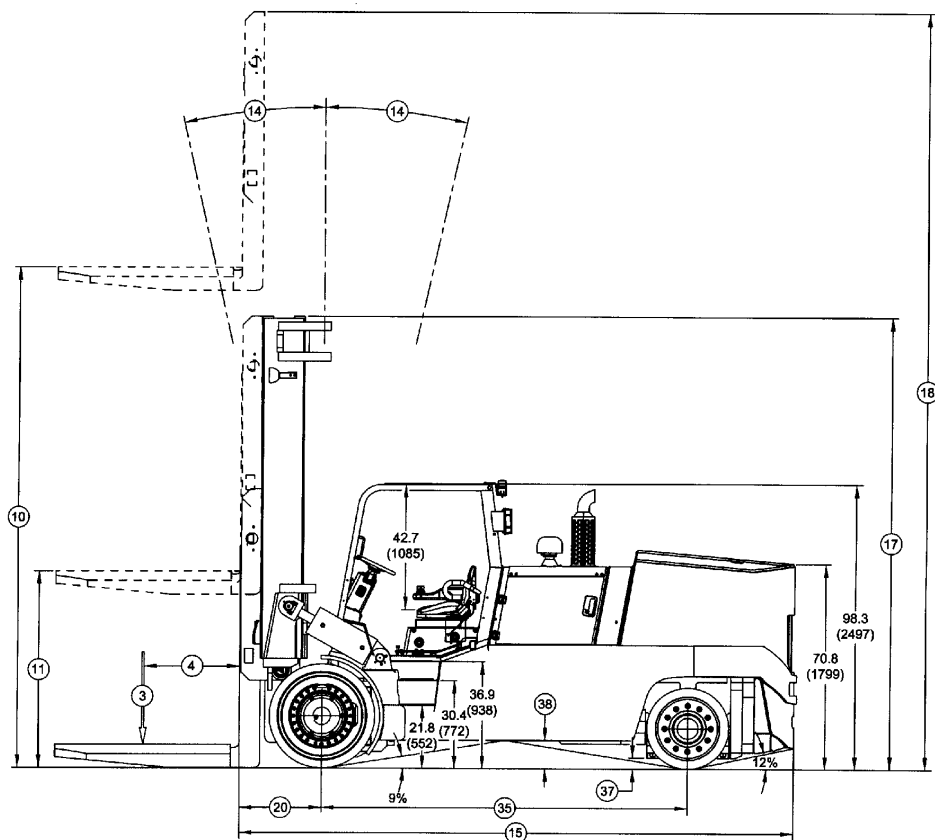

Mast options*

Low height: in (mm)	Maximum fork height: in (mm)	freelift: in. (mm)
F600@40, F650@36, F700@36 wide view monomast (recommended for LH seat position)		
126 (3200)	48.5 (1232)	48.5 (1232)
F750@36, F800@36, F800@40 wide view monomast (recommended for LH seat position)		
156 (3962)	70.5 (1791)	70.5 (1797)

*Other mast options are available. Please consult factory for more information.



MADE WITH PRIDE
IN THE USA